

FRONT VIEW

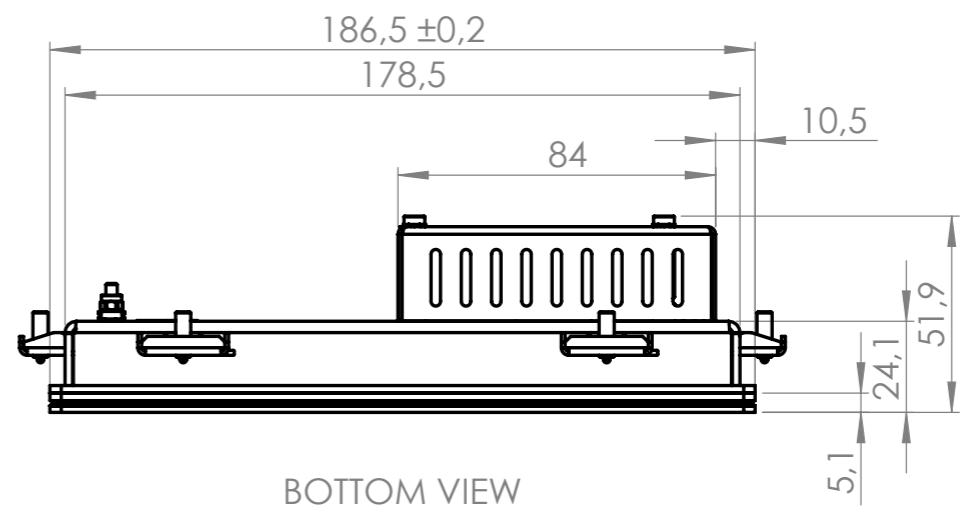

BOTTOM VIEW

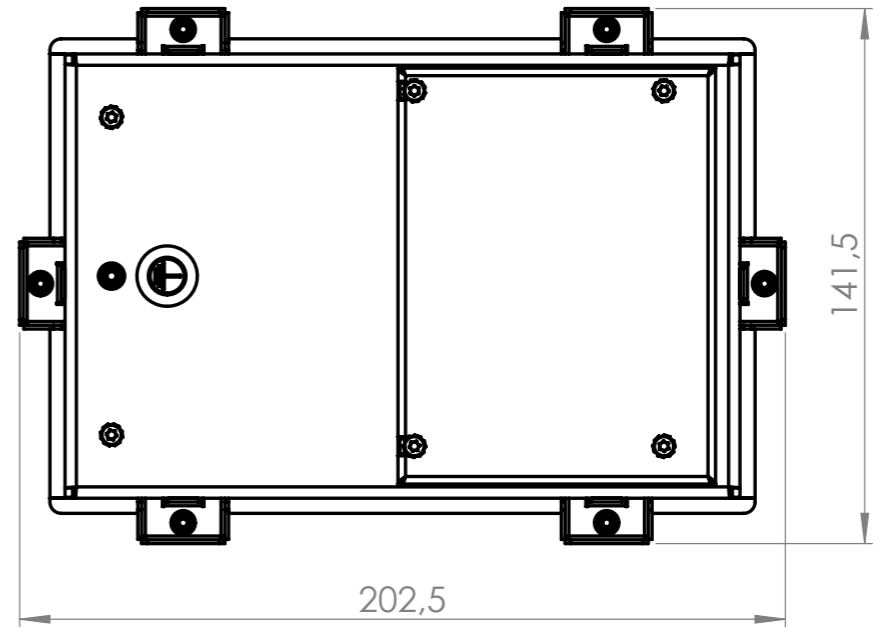

BACK VIEW

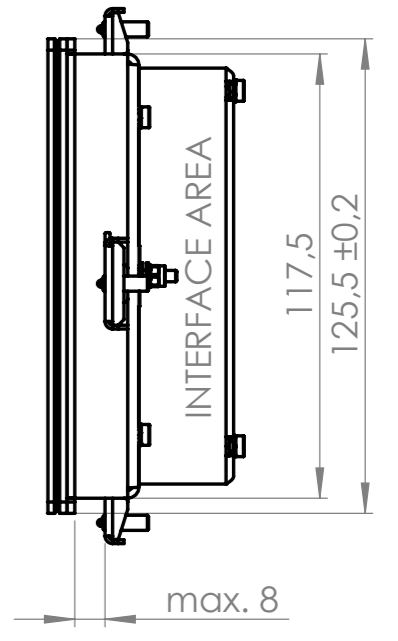

SIDE VIEW

Drawing for illustration of mechanical measurements only.  
For more details see datasheet.

General tolerances DIN ISO 2768-mK		Drawn by: PL	Material:
Document type: general arrangement drawing		Proved by: PL	Raw material:
		Release date: 2020-07-06	Surface treatment:
			Scale: 1:2
			Touch-it Open Frame glass 7 Übersichtszeichnung
Rev.	Date	Name	Page: 1/2
			PA10006164
			A3

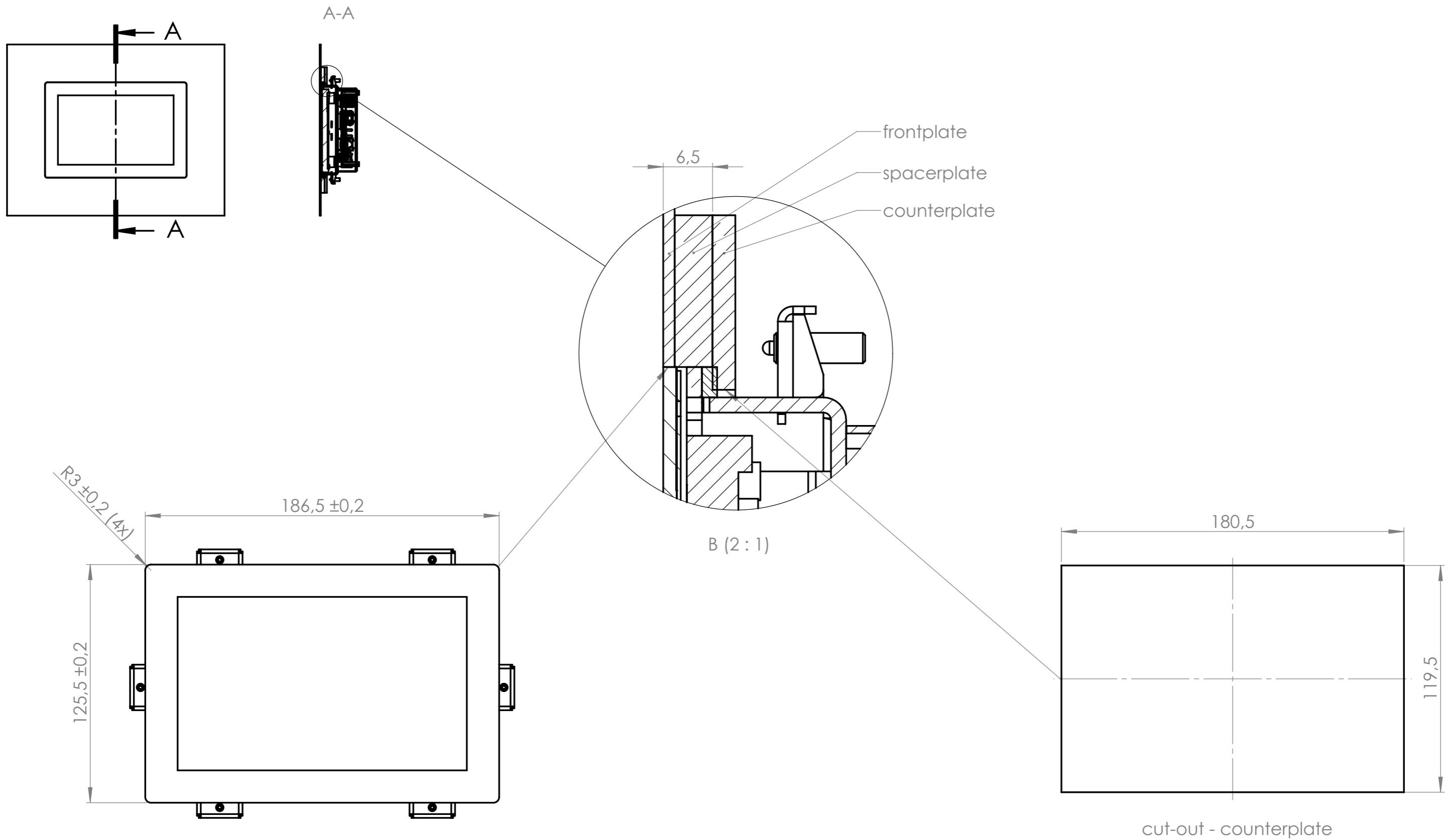

cut-out - front- & spacerplate\*

cut-out - counterplate

\* The actual cut-out-dimensions of the front- and spacerplate need to be subject to the prevalant assembly situation (production tolerances, ambient temperature, etc.) and therefore to be defined by the customer.

General tolerances DIN ISO 2768-mK		Drawn by: PL	Material:	
Document type: general arrangement drawing		Proved by: PL	Raw material:	Scale: 1:5
		Release date: 2020-07-06	Surface treatment:	
			Touch-it Open Frame glass 7 Übersichtszeichnung	
Rev.	Date		Name	Page: 2/2
			PA10006164	A3
Proprietary notice ISO 16016 to be considered				