

General tolerances DIN ISO 2768-mK			Drawn by: CH	Drawing for mechanical measurements only. For more details see datasheet.	
Document type: general arrangement drawing			Proved by: JT	Article designation: Touch Industrial Open Frame 7	
			Release date: 2022-05-10		
				Drawing number: PA10010861	Scale: 1:2
Rev.	Date	Name			Page: 1/2
Proprietary notice ISO 16016 to be considered					
					A3

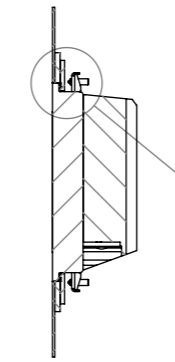

A-A (1 : 5)

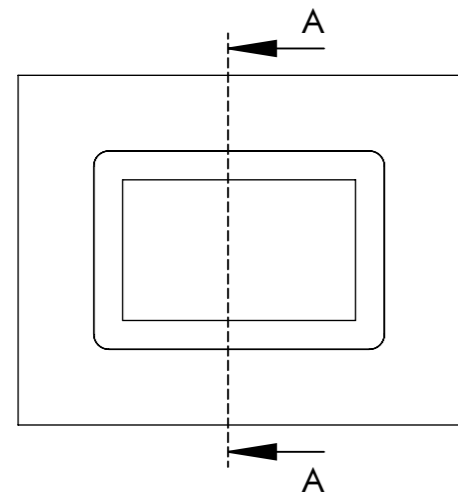
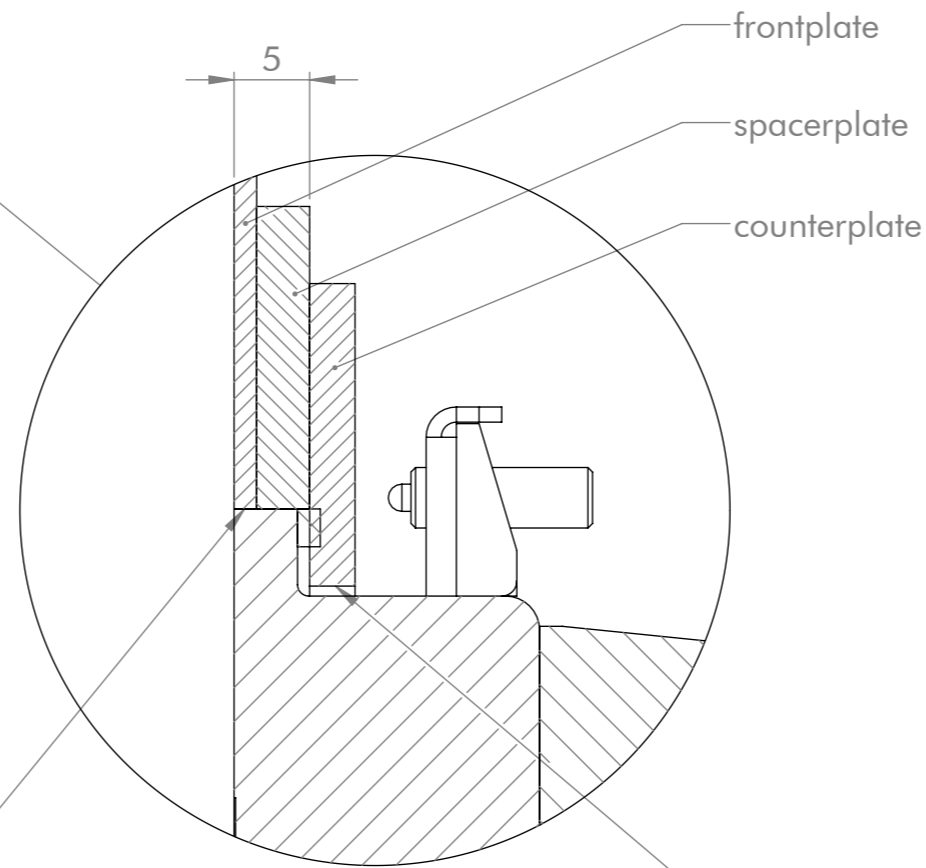

DETAIL B
SCALE 2 : 1

frontplate

spacerplate

counterplate

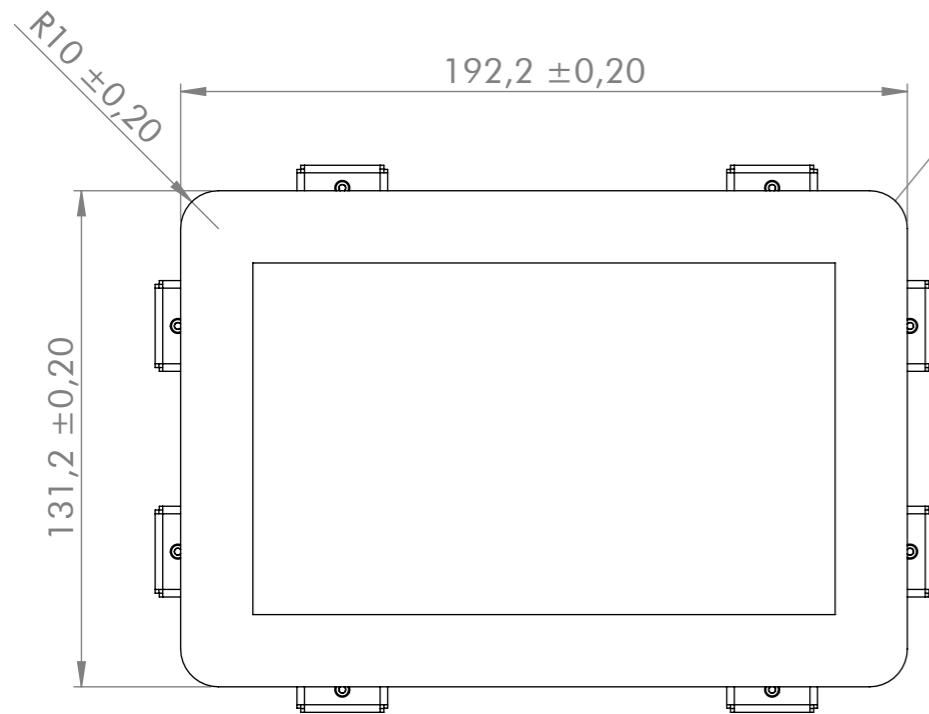

cut-out front- & spacerplate*

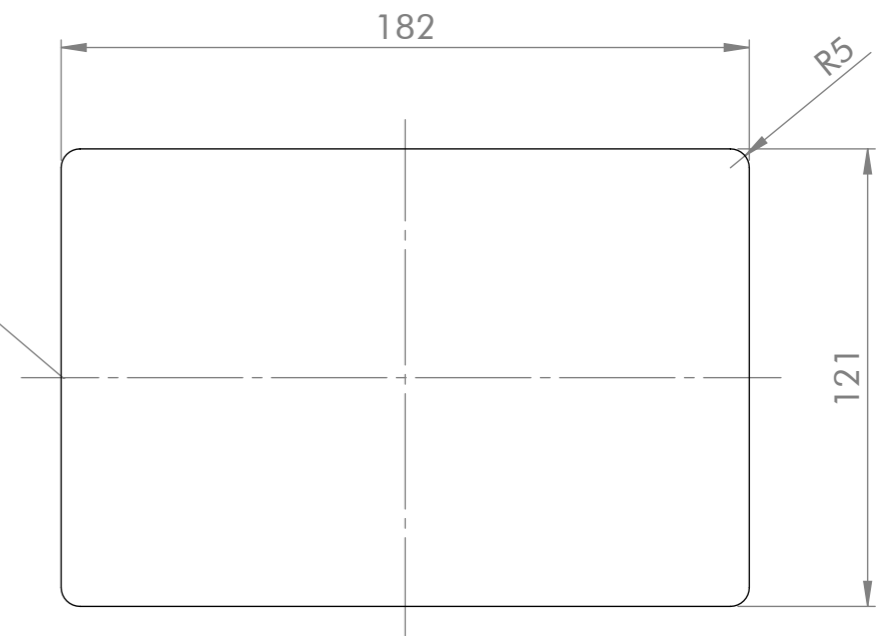

cut-out counterplate

* The actual cut-out-dimensions of the front- and spacerplate need to be subjected to the prevalent assembly situation (production tolerances, ambient temperature, etc.) and therefore to be defined by the customer.

General tolerances DIN ISO 2768-mK			Drawn by: CH	Drawing for mechanical measurements only. For more details see datasheet.	
Document type: general arrangement drawing			Proved by: JT	Article designation: Touch Industrial Open Frame 7	
			Release date: 2022-05-10		
				Drawing number: PA10010861	Scale: 1:2
Rev.	Date	Name			Page: 2/2
Proprietary notice ISO 16016 to be considered					A3