

3  
holes inside housing for  
thread forming screws  
2x  $\varnothing 2,75 \downarrow 4$

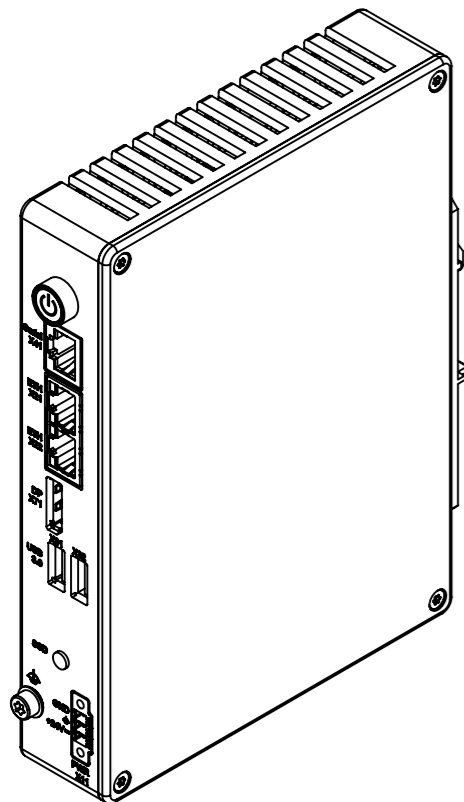
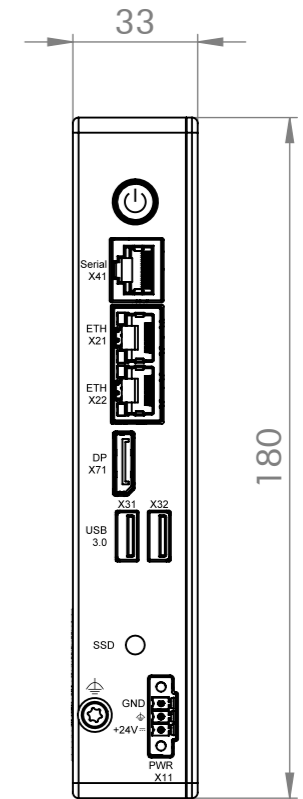
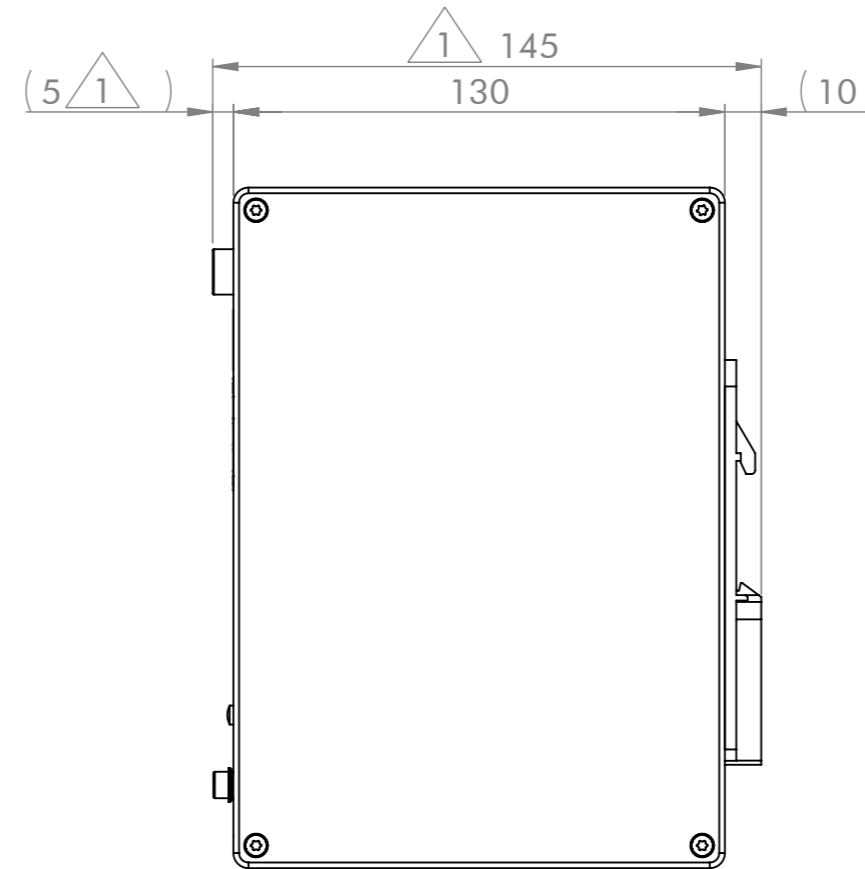
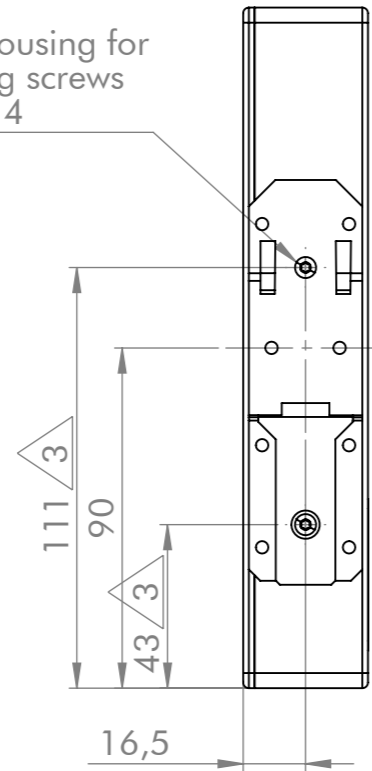

General tolerances DIN ISO 2768-mK			Drawn by: AH	Drawing for mechanical measurements only. For more details see datasheet.	
Document type: general arrangement drawing			Proved by: AH	Article designation: Industrial PC Argon	
			Release date: 2022-01-26		
03	2022-01-11	JT		Drawing number: PA10005620	Scale: 1:2
02	2021-02-24	AH			Page: 1/1
01	2020-07-07	AH			A3
Rev.	Date	Name	Proprietary notice ISO 16016 to be considered		